

selec



OGC®

selec[®]



SELEC

La Serie SELEC, es un completo sistema para divisiones de oficina, integrando paneles fijos y puertas practicables enmarcadas.

El conjunto de perfiles que forman parte de SELEC dan soluciones a instalar fijos de vidrios de grandes espesores como vidrios de cámara o laminados de hasta 16 mm. Así mismo el marco para las hojas practicables ofrece una excelente versatilidad para su montaje permitiendo ajustar las bisagras con las tuercas en T guiadas sin necesidad de taladrar el perfil.

El sistema dispone de una completa gama de accesorios y juntas de acristalar, para los diferentes espesores de vidrio.

A Série SELEC é um sistema completo para divisões de escritório, integrando painéis fixos e portas com moldura viável.

O conjunto de perfis que fazem parte da SELEC oferece soluções para instalação de vidros de espessuras fixas como câmara ou laminado de até 16 mm. Da mesma forma, a moldura das folhas abríveis oferece excelente versatilidade de montagem, permitindo que as dobradiças sejam ajustadas com as porcas T guiadas sem a necessidade de furação do perfil.

O sistema possui uma gama completa de acessórios e juntas de envidraçamento, para diferentes espessuras de vidro.

The SELEC Series is a complete system for office divisions, integrating fixed panels and framed practicable doors.

The set of profiles that are part of SELEC provide solutions to install fixed glass of large thicknesses such as chamber or laminated glass up to 16 mm. Likewise, the frame for the practicable blades offers excellent versatility for assembly, allowing the hinges to be adjusted with the guided T-nuts without drilling the profile.

The system has a complete range of accessories and glazing joints, for different glass thicknesses.

La série SELEC est un système complet pour les divisions de bureaux, intégrant des panneaux fixes et des portes praticables encadrées.

L'ensemble de profilés qui font partie de SELEC fournit des solutions pour installer des épaisseurs de verre fixes telles que la chambre ou le verre feuilleté jusqu'à 16 mm. De même, le cadre pour les vantaux ouvrants offre une excellente polyvalence de montage, permettant de régler les charnières avec les écrous en T guidés sans avoir besoin de percer le profilé.

Le système dispose d'une gamme complète d'accessoires et de joints de vitrage, pour différentes épaisseurs de verre.





Paredes de vidrio con mínima periferia de aluminio.
Esa es la esencia, donde el dentro y el fuera se diluyen bajo
una nueva filosofía de ambientes funcionales y versátiles.

Glass walls with minimal aluminum profiles,
That is the essence, where the inside and the outside are
diluted under a new philosophy of functional and versatile
environments.



inout

Selec se une a una nueva filosofía de conexión de espacios, donde los límites de los conceptos interior y exterior se difuminan y fusionan.

Selec joins a new philosophy of connection of spaces, where the limits of the interior and exterior concepts blur and merge.

selec

La Serie Selec surge de la idea de un nuevo concepto de ambientes en general y más en particular para oficinas.

Más flexible y orgánico, con nuevos conceptos de divisiones espaciales en el entorno de trabajo, en el que los límites entre dentro-fuera, interior-exterior se diluyen en el global del entorno, sumándose a una tendencia menos física y más funcional. Selec ofrece soluciones completamente actuales para las nuevas concepciones de espacios de trabajo, un nuevo concepto de paredes transparentes de vidrio, erigiéndose como una liviana y sutil forma de delimitar volúmenes sin obstáculos visuales.

Una gama de opciones de marcos con galce, perfiles en T y diferentes junquillos que permiten la realización de salas estanco, tanto térmica como acústicamente, con dimensiones de perfiles mínima.

The Selec Series arises from the idea of a new concept of environments in general and more in particular for offices.

More flexible and organic, with new concepts of spatial divisions in the work environment, in which the limits between inside-outside, inside-outside are diluted in the global environment, adding to a less physical and more functional trend. Selec offers completely up-to-date solutions for new conceptions of workspaces, a new concept of transparent glass walls, establishing itself as a light and subtle way to delimit volumes without visual obstacles.

A range of options of frames with galce, T-profiles and different junquills that allow the realization of watertight rooms, both thermally and acoustically, with minimum profile dimensions





black

Selec Black, una versión acabado en anodizado negro mate de 15 micras y con un leve lijado, le otorga una alta resistencia y durabilidad que se suma a un fácil mantenimiento. Se presenta como una opción para ambientes de vanguardia, donde destaca por su marcado y sofisticado carácter, aportando a los ambientes donde se integra un estilo "urban chic" elegante.

Selec Black, a version finished in 15 micron matte black anodized and with a light sanding, gives it high resistance and durability that adds to easy maintenance. It is presented as an option for avant-garde environments, where it stands out for its marked and forceful character, contributing to environments where a high level of sober elegance is integrated.

Silver

Selec Silver, versión acabado en anodizado plata mate de 15 micras, de un aspecto aterciopelado de alta calidad, dotando de gran durabilidad y resistencia a la superficie del perfil. Una opción neutra para una perfecta mimetización e integración, con el ambiente, sin restar papel protagonista al resto de elementos del entorno con los que coexiste.

Selec Silver, version finished in 15 micron matt silver anodized, with a high-quality velvety appearance, providing great durability and resistance to the profile surface. A neutral option for a perfect blend and integration, with the environment, without detracting from the leading role of the rest of the elements of the environment in which it coexists.





acristala hasta 30mm

Hemos querido con Selec el ofrecer el más amplio abanico de posibilidades cuando pensamos en delimitar un espacio.

Las paredes de vidrio sustituyen a las convencionales de obra, vidrios de grandes prestaciones y de avanzada tecnología para hacer ambientes completamente aislados y confortables.

Opciones como las de aislar térmica y acústicamente una sala es posible gracias a los diferentes espesores de vidrio que puede albergar nuestra serie Selec, disponiendo de perfiles de junquillo para gruesos desde 10mm. hasta 30mm., lo que permite elegir entre las diversas opciones de acristalar con vidrio técnicos, para estos fines, que van desde los laminado con butyral con propiedades de reducción sonora hasta vidrios de cámara control solar y térmico de avanzada tecnología.

We have wanted with Selec to offer the widest range of possibilities when we think about delimiting a space.

Glass walls replace conventional works, high-performance glass and advanced technology to make completely isolated and comfortable environments.

Options such as those for thermally and acoustically insulating a room are possible thanks to the different thicknesses of glass that our Selec series can house, having reed profiles for thicknesses from 10mm. up to 30mm., allowing you to choose between the various glazing options with technical glass, for these purposes, ranging from laminates with butyral with noise reduction properties to advanced technology solar and thermal control chamber glasses.



1F+ 1F 90°

SERIE UNE
 INSTALACIÓN VIDRIOS FIJOS A 90°,
 ESCUADRAS REF. 10.191210.00
 UNE SERIES
 INSTALLATION OF FIXED GLASSES AT 90°,
 BRACKETS REF. 10.191210.00



1F + 1F 135°

SERIE UNE
 INSTALACIÓN VIDRIOS FIJOS A 135°,
 ESCUADRAS REF. 10.191211.00
 UNE SERIES
 INSTALLATION OF FIXED GLASSES AT 135°,
 BRACKETS REF. 10.191211.00

colors

11 Negro mate

09 Blanco mate

04 Anod. plata

06 Anod. negro

11

09

04

06

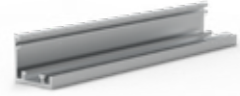

13.260706
PERFIL MARCO FIJOS SELEC

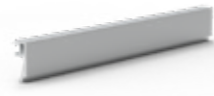

13.260606
JUNQUILLO SELEC GRUESO VIDRIO 5+5 - 6+6

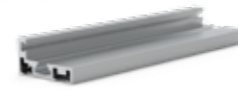

13.220017
MARCO PUERTA 51MM



10.191211.00
ESCUADRA PLANA 135°

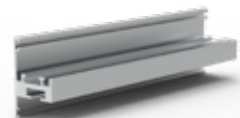

13.260906
PERFIL T PUERTA SELEC

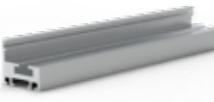

13.260806
PERFIL MARCO PUERTA SELEC



10.191210.00
ESCUADRA 90° PLANA



10.210722.00
ESCUADRA ALINEAMIENTO MARCO

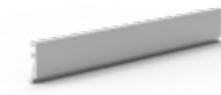

13.261006
JUNQUILLO GRUESO VIDRIO 8+8

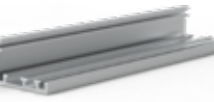

13.261106
PERFIL MARCO FIJOS SELEC (Vidrios de Cámara hasta 30mm)



40.005253.00
JUNTA PERFIL MARCO



40.005127.00 100 m
40.132468.00 10 m
JUNTA CUÑA EPDM 3MM.

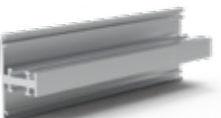

13.261206
PERFIL T FIJOS

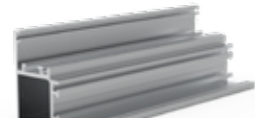

13.211400
PERFIL ESQUINERO



40.005129.00 100m
40.138975.00 10m



40.191218.00 6m
JUNTA MARCO PUERTA



40.200110.00 NEGRA
40.200111.00 GRIS
JUNTA RANURA PERFIL MARCO Y PERFIL T MARCO HOJA.

40.220521.00 NEGRA
40.220522.00 GRIS
JUNTA MARCO 220017



13.271812.00
ESCUADRA 90°

40.001084.00
CALZOS VIDRIO



12.210712
BISAGRA SIMPLE

12.210713
CERRADURA GOLPE Y LLAVE



12.210715
CERRADURA GOLPE

10.191217.00
CERRADERO



12.220317
JUEGO BISAGRAS PIVOTANTES APERTURAS 1-3

12.220318
JUEGO BISAGRAS PIVOTANTES APERTURAS 2-4



22002100
NORMALIZADO 45*45*1,3

22002100
NORMALIZADO 45*15*1,5



22111000
Set escuadras jamba pivot y marco selec 51

13.212800
PERFIL MARCO SIN GALCE.

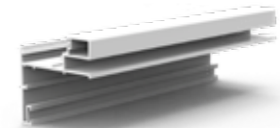

13.212700
MARCO COMPENSACIÓN

13.221500
MARCO GALCE



13.221600
TAPETA MARCO GALCE

40.220209.00
ESCUADRA AINEACIÓN FUJI.

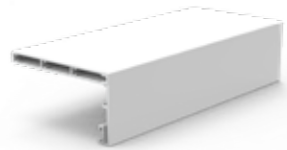

22002600
MARCO COMPENSACIÓN

22002700
MARCO COMPENSACIÓN



23021800
CERRADERO MARCO 51

CARACTERÍSTICAS TÉCNICAS
TECHNICAL CHARACTERISTICS

DIMENSIONES SECCIÓN
SECTION DIMENSIONS

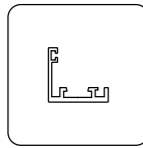

30 X 33 MM

PERFIL MARCO FIJOS
Perfil para la construcción de marcos fijos
Profile for the construction of fixed frames

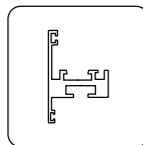

51 X 33 MM

PERFIL "T" PUERTA
Perfil "T" para la construcción de marcospuerta intermedios.
"T" profile for the construction of door frames intermediate..

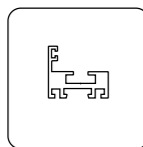

29 X 33 MM

PERFIL MARCO PUERTA
Perfil para la construcción de Puertas lateralmente en los marcos fijos.
Profile for the construction of doors laterally in fixed frames.

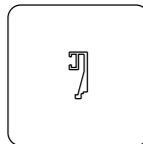

22 X 10 MM

JUNQUILLO
Junquillo para la colocación de vidrio 10-12mm
10-12 mm glass placement profile

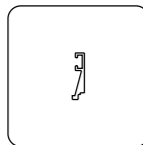

22 X 5 MM

JUNQUILLO
Perfil para la colocación de vidrio 16 o posibilidad de colocación vidrio camara hasta 16mm
Profile for the placement of glass 16 or the possibility of placing glass camera up to 16mm

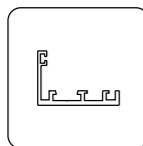

30 X 45 MM

PERFIL MARCO FIJOS (VIDRIO DE CÁMARA)
Perfil para la construcción de marcos fijos con vidrio de cámara hasta 30mm
Profile for the construction of fixed frames with camera glass up to 30mm

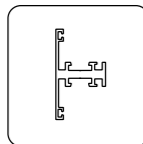

60 X 33 MM

PERFIL "T"
Perfil para la construcción fijos
Profile for fixed construction

CARACTERÍSTICAS TÉCNICAS
TECHNICAL CHARACTERISTICS

DIMENSIONES SECCIÓN
SECTION DIMENSIONS

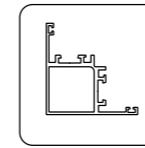

63 X 63 MM

PERFIL ESQUINERO
Perfil para la construcción de marcos fijos
Profile for the construction of fixed frames

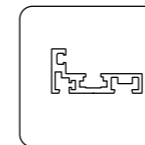

25 X 51 MM

PERFIL MARCO PUERTA
Perfil para la construcción de puertas dentro del sistema selec con marco cámara o puertas independientes.
Profile for the construction of doors within the select system with chamber frame or independent doors.



UNE FIJOS
UNE FIXO
UNE FIXED
UNE FIXÉ

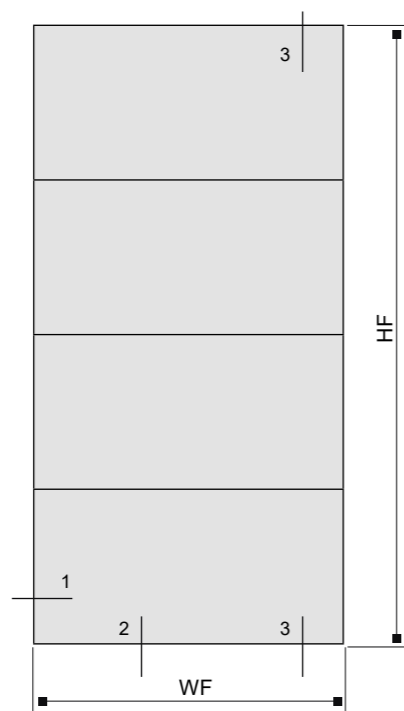

Perfiles
Perfis
Profiles
Profils

13.260700		2	HF	
		2	WF	
13.260600		2	HF-60	
		2	WF-16	
22001900		6	WF-60	
40.005264.00		2	HF	-
		2	WF	-
GLASS		1	HF-30	-
			WF-30	-

Accesorios
Acessórios
Accessories
Accessoires

10.191209.00	ESCUADRA 90°	4
40.001084.00	CALZOS VIDRIO SELEC	2
40.001270.00	CINTA DOBLE CARA 3M	12 WF
10.210722.00	ESCUADRA ALINEAMIENTO MARCO	4

UNE FIJOS
UNE FIXO
UNE FIXED
UNE FIXÉ

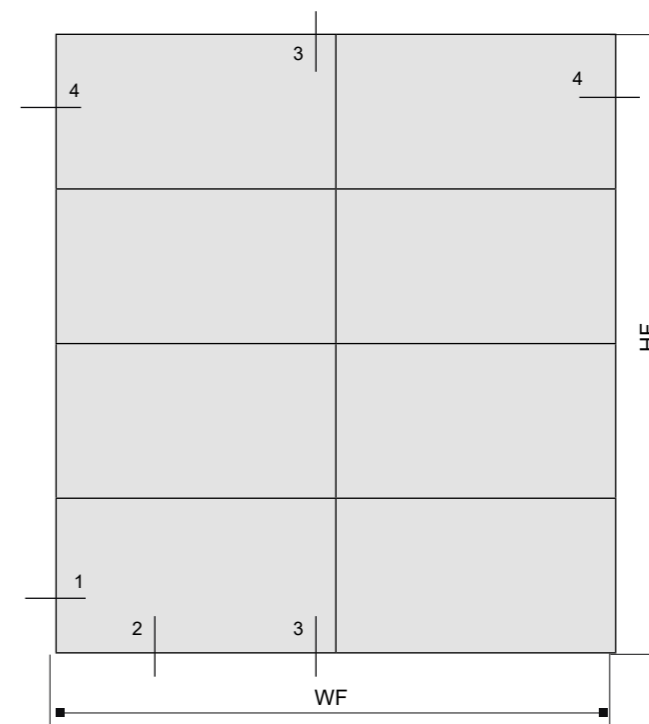

Perfiles
Perfis
Profiles
Profils

13.260700		2	HF	
		2	WF	
13.260600		4	HF-60	
		4	WF-32/2	
22001900		12	WF-120/2	
13.261200		1	HF-16	
40.005264.00		4	HF	-
		2	WF	-
GLASS		1	HF-30	-
			WF-120/2 +30	-

Accesorios
Acessórios
Accessories
Accessoires

10.191209.00	ESCUADRA 90°	6
40.001084.00	CALZOS VIDRIO SELEC	4
40.001270.00	CINTA DOBLE CARA 3M	12 WF
10.210722.00	ESCUADRA ALINEAMIENTO MARCO	4

UNE FIJOS
UNE FIXO
UNE FIXED
UNE FIXÉ

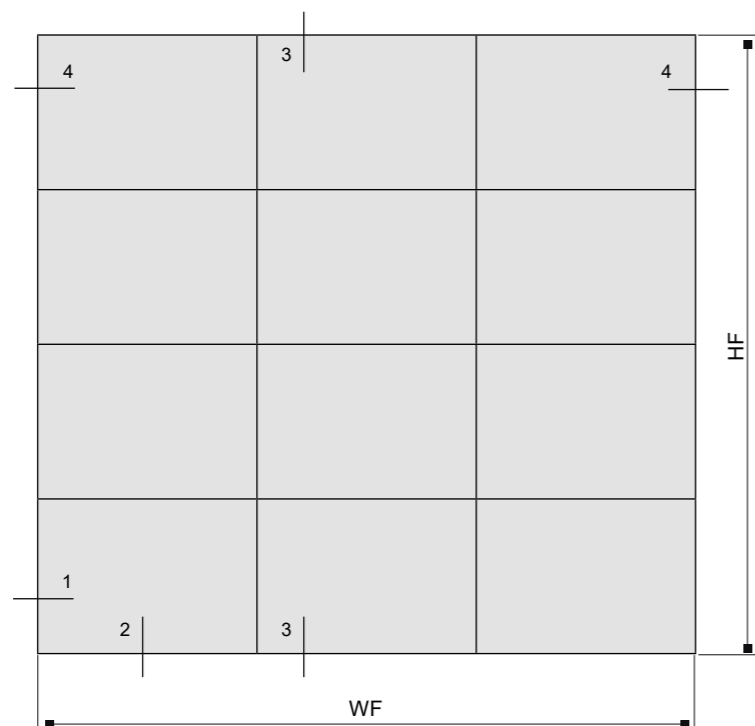

Perfiles
Perfis
Profiles
Profils

13.260700		2	HF	
		2	WF	
13.260600		6	HF-60	
		6	WF-48/3	
22001900		18	WF-180/3	
13.261200		2	HF-16	
40.005264.00		6	HF	-
		2	WF	-
GLASS		1	HF-30	-
			WF-180/3 +30	-

Accesorios
Accessórios
Accessories
Accessoires

10.191209.00	ESCUADRA 90°	8
40.001084.00	CALZOS VIDRIO SELEC	6
40.001270.00	CINTA DOBLE CARA 3M	12 WF
10.210722.00	ESCUADRA ALINEAMIENTO MARCO	4

UNE FIJOS
UNE FIXO
UNE FIXED
UNE FIXÉ

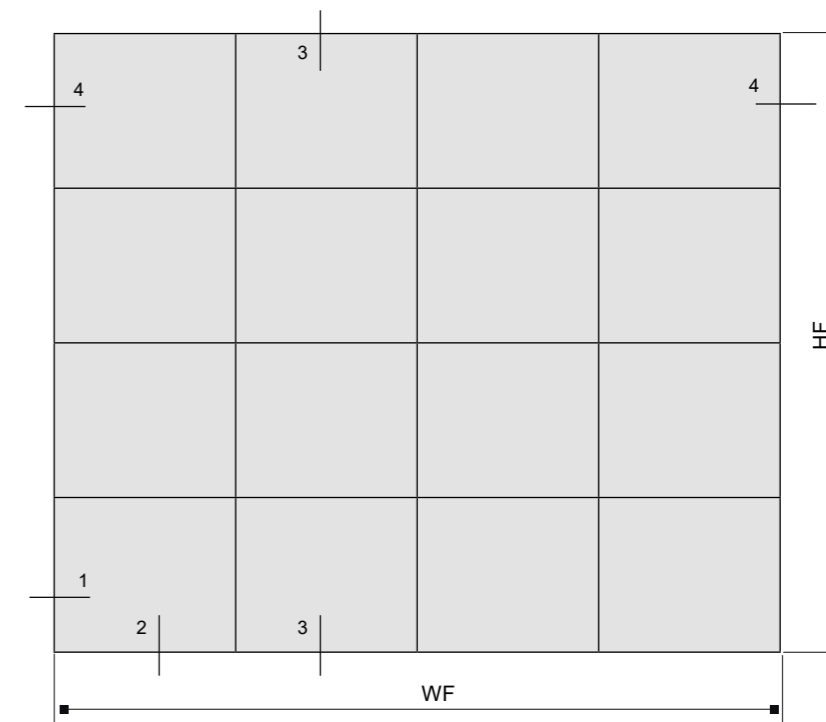

Perfiles
Perfis
Profiles
Profils

13.260700		2	HF	
		2	WF	
13.260600		8	HF-60	
		8	WF-64/4	
22001900		24	WF-240/4	
13.261200		3	HF-16	
40.005264.00		8	HF	-
		2	WF	-
GLASS		1	HF-30	-
			WF-240/4 +30	-

Accesorios
Accessórios
Accessories
Accessoires

10.191209.00	ESCUADRA 90°	10
40.001084.00	CALZOS VIDRIO SELEC	8
40.001270.00	CINTA DOBLE CARA 3M	12 WF
10.210722.00	ESCUADRA ALINEAMIENTO MARCO	4

UNE FIJOS
UNE FIXO
UNE FIXED
UNE FIXÉ

Vistas marcos fijos

Vistas de quadros fixos
Fixed frame views
Vues à cadre fixe

Sección 1-1

Seção 1-1
Section 1-1
Section 1-1

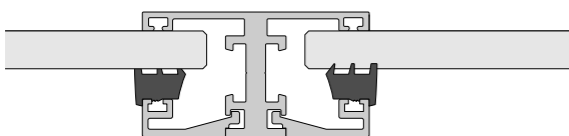

Sección 2-2

Seção 2-2
Section 2-2
Section 2-2

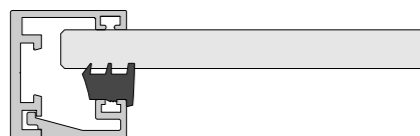

Sección 4-4

Seção 4-4
Section 4-4
Section 4-4

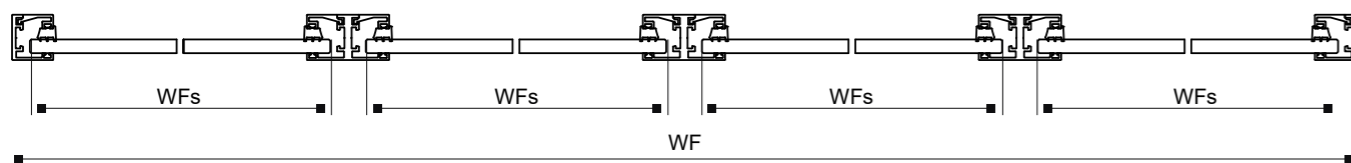

Sección 3-3

Seção 2-2
Section 2-2
Section 2-2



SELEC FIJOS
SELEC FIXO
SELEC FIXED
SELEC FIXÉ

Despiece, componentes

Vista explodida, componentes
Exploded view, components
Vue éclatée, composants

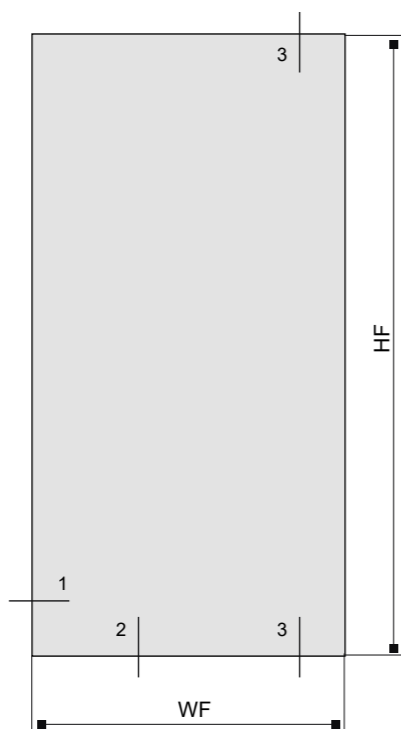

Perfiles

Perfis
Profiles
Profils

13.260706		2	HF	
		2	WF	
13.260606		2	HF-60	
		2	WF-16	
40.005253.00		2	HF	-
		2	WF	-
40.005129.00		2	HF	-
		2	WF	-
GLASS		1	HF-30	-
			WF-30	-

Accesorios

Accessórios
Accessories
Accessoires

10.191209.00	ESCUADRA 90°	4
40.001084.00	CALZOS VIDRIO SELEC	2

Muy importante

Las referencias en este esquema son para vidrio 5+5, para otros espesores consultar junquillo y juntas de cuña.

SELEC FIJOS
SELEC FIXO
SELEC FIXED
SELEC FIXÉ

Despiece, componentes

Vista explodida, componentes
Exploded view, components
Vue éclatée, composants

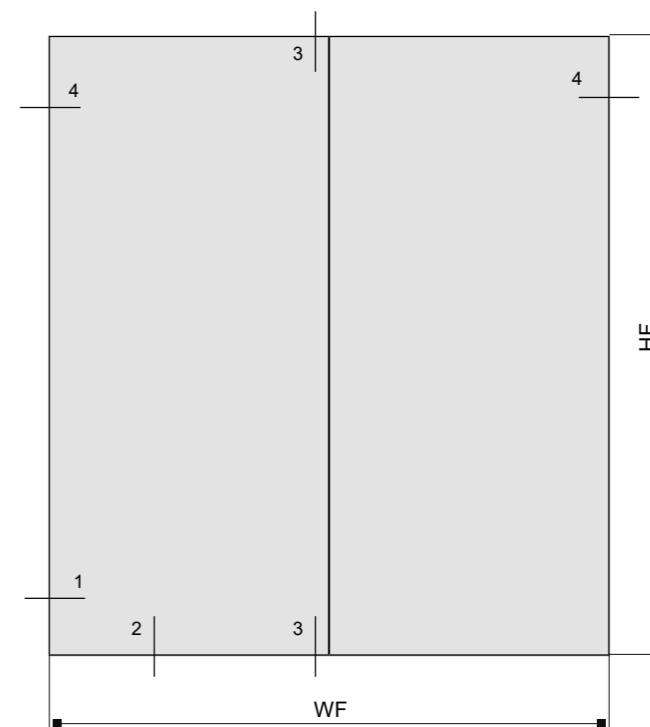

Perfiles

Perfis
Profiles
Profils

13.260706		2	HF	
		2	WF	
13.260606		4	HF-60	
		4	WF-16	
13.261206		1	HF-16	
40.005253.00		4	HF	-
		2	WF	-
40.005129.00		4	HF	-
		2	WF	-
GLASS		2	HF-30	-
			WF-120/2 + 30	-

Accesorios

Accessórios
Accessories
Accessoires

10.191209.00	ESCUADRA 90°	6
40.001084.00	CALZOS VIDRIO SELEC	4

SELEC FIJOS
SELEC FIXO
SELEC FIXED
SELEC FIXÉ

Despiece, componentes

Vista explodida, componentes
Exploded view, components
Vue éclatée, composants

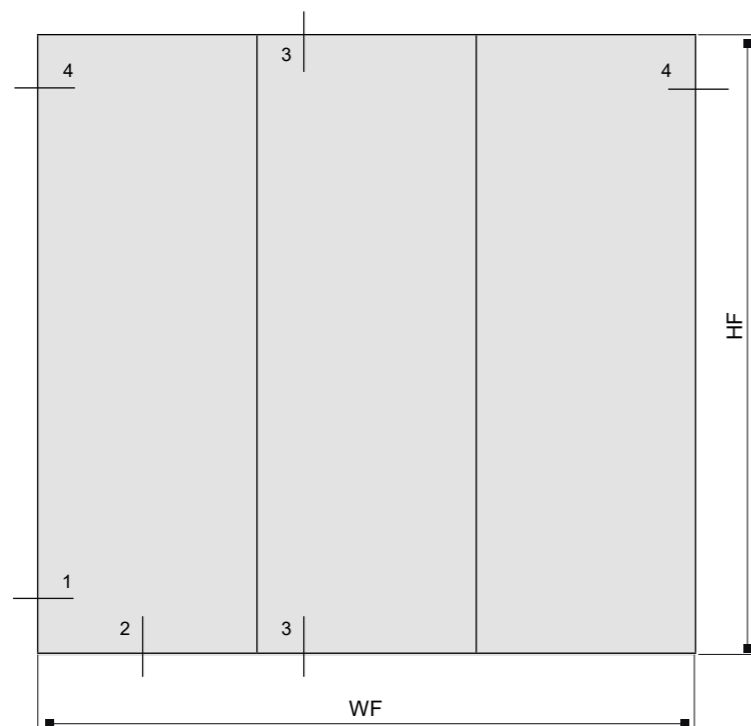

Perfiles

Perfis
Profiles
Profils

13.260706		2	HF	
		2	WF	
13.260606		6	HF-60	
		6	WF-16	
13.261206		2	HF-16	
40.005253.00		6	HF	-
		2	WF	-
40.005129.00		6	HF	-
		2	WF	-
GLASS		3	HF-30	-
			WF-180/3 + 30	

Accesorios

Acessórios
Accessories
Accessoires

10.191209.00	ESCUADRA 90°	8
40.001084.00	CALZOS VIDRIO SELEC	6

SELEC FIJOS
SELEC FIXO
SELEC FIXED
SELEC FIXÉ

Despiece, componentes

Vista explodida, componentes
Exploded view, components
Vue éclatée, composants

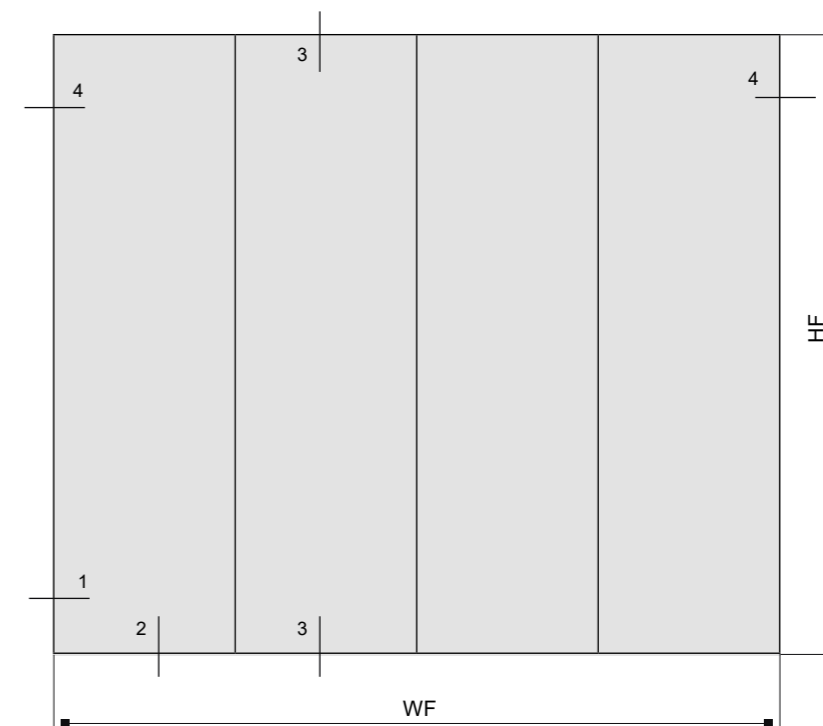

Perfiles

Perfis
Profiles
Profils

13.260706		2	HF	
		2	WF	
13.260606		8	HF-60	
		8	WF-16	
13.261206		3	HF-16	
40.005253.00		8	HF	-
		2	WF	-
40.005129.00		8	HF	-
		2	WF	-
GLASS		4	HF-30	-
			WF-240/4 + 30	

Accesorios

Acessórios
Accessories
Accessoires

10.191209.00	ESCUADRA 90°	10
40.001084.00	CALZOS VIDRIO SELEC	8

SELEC PUERTA
SELEC PORTA
SELEC DOOR
SELEC PORTE

Despiece, componentes

Vista explodida, componentes
 Exploded view, components
 Vue éclatée, composants

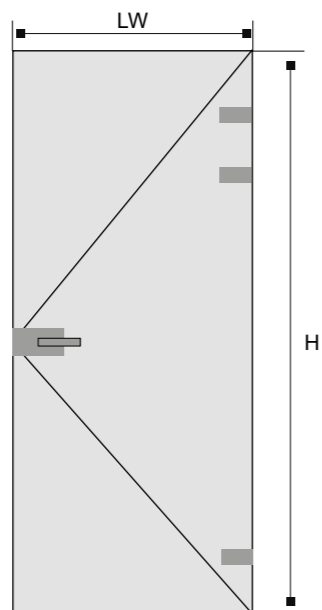

Perfiles

Perfis
 Profiles
 Profils

Accesorios

Accessórios
 Accessories
 Accessoires

13.260806		1	H	
		1	H	
		1	LW= OW-WF	
40.191218.00		2	H	-
		1	LW	-
40.200110.00		2	H	-
		1	LW	-
GLASS DOOR		1	H-32	-
			LW-42	-

10.191209.00	ESCUADRA 90°	2
10.191217.00	CERRADERO	1
12.210712	BISAGRA SIMPLE	3
12.210713	CERRADURA GOLPE Y LLAVE	1

SELEC PUERTA LATERAL Y FIJOS
SELEC A PORTA LATERAL E FIXA
SELEC SELECT SIDE DOOR AND FIXED
SELEC PORTE LATÉRALE ET FIXÉ

Despiece, componentes

Vista explodida, componentes
 Exploded view, components
 Vue éclatée, composants

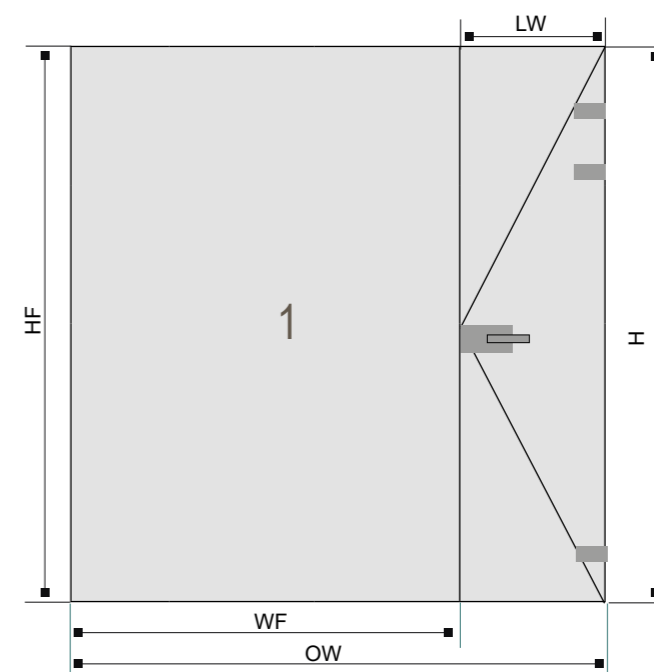

Perfiles

Perfis
 Profiles
 Profils

Accesorios

Accessórios
 Accessories
 Accessoires

13.260706		2	HF	
		2	WF	
13.260606		2	HF-60	
		2	WF-16	
40.005253.00		2	HF	-
		2	WF	-
40.005129.00		2	HF	-
		2	WF	-
13.260806		1	H	
		1	H	
		1	LW= OW-WF	
40.191218.00		2	H	-
		1	LW	-
40.200110.00		2	H	-
		1	LW	-
GLASS FIXED 1		1	HF-30	-
			WF-30	-
GLASS DOOR		1	H-32	-
			LW-42	-

10.191209.00	ESCUADRA 90°	6
10.191217.00	CERRADERO	1
12.210712	BISAGRA SIMPLE	3
12.210713	CERRADURA GOLPE Y LLAVE	1
40.001084.00	CALZOS VIDRIO	2

SELEC PUERTA LATERAL Y FIJOS
SELEC A PORTA LATERAL E FIXA
SELEC SIDE DOOR AND FIXED
SELEC PORTE LATÉRALE ET FIXE

Despiece, componentes

Vista explodida, componentes
 Exploded view, components
 Vue éclatée, composants

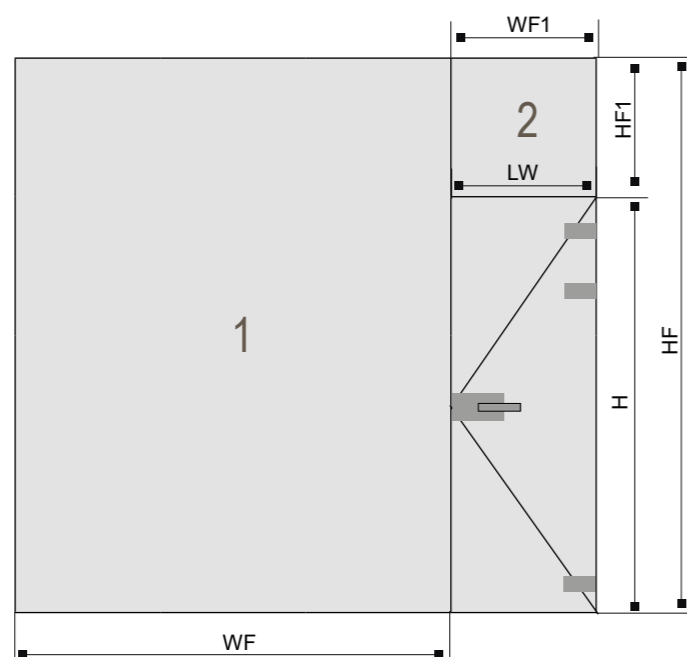

Perfiles

Perfis
 Profiles
 Profils

13.260706		2	HF	
		2	WF	
		2	HF1	
		2	WF1	
13.260606		2	HF-60	
		2	WF-16	
		2	HF1-60	
		2	WF1-16	
40.005253.00		2	HF	-
		2	WF	
		2	HF1	
		2	WF1	
40.005129.00		2	HF	-
		2	WF	
		2	HF1	
		2	WF1	
13.260806		1	H= HF-HF1	
		1	H= HF-HF1	
		1	LW= OW-WF	

40.191218.00		2	H	-
		1	LW	-
40.200110.00		2	H	-
		1	LW	-
GLASS FIXED 1		1	HF-30	-
			WF-30	-
GLASS FIXED 2		1	HF1-30	-
			WF1-30	-
GLASS DOOR		1	H-32	-
			LW-42	-

Accesorios

Accessórios
 Accessories
 Accessoires

10.191209.00	ESCUADRA 90°	10
10.191217.00	CERRADERO	1
12.210712	BISAGRA SIMPLE	3
12.210713	CERRADURA GOLPE Y LLAVE	1
40.001084.00	CALZOS VIDRIO	4

SELEC PUERTA LATERAL Y FIJOS
SELEC A PORTA LATERAL E FIXA
SELEC SIDE DOOR AND FIXED
SELEC PORTE LATÉRALE ET FIXE

Despiece, componentes

Vista explodida, componentes
 Exploded view, components
 Vue éclatée, composants

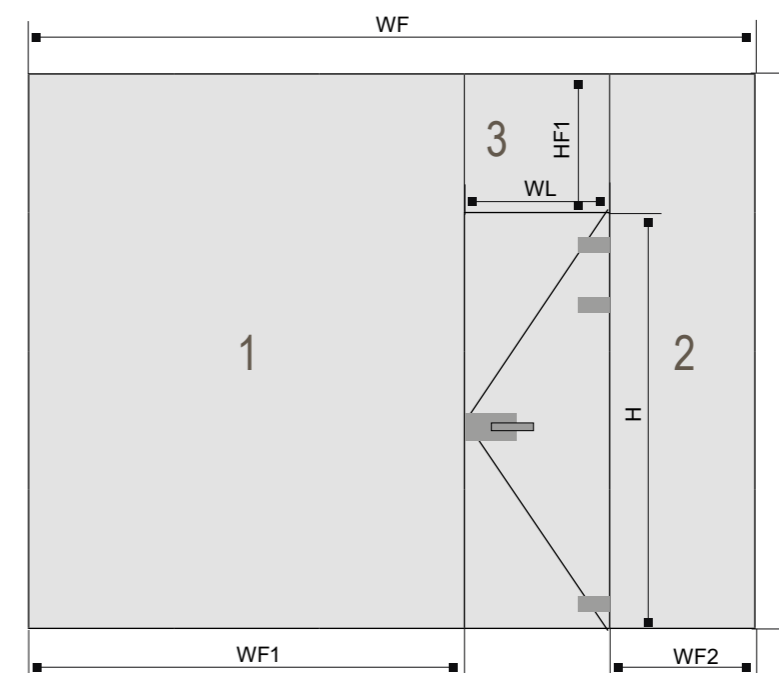

Perfiles

Perfis
 Profiles
 Profils

13.260706		2	HF	
		1	WF	
		1	WF1	
		1	WF2	
13.260606		2	HF-60	
		2	WF-16	
		1	WF1-8	
		1	WF2-8	
		1	(H-HF1)-8	
		1	(H-HF1)-8	
13.260906		1	H= (HF-HF1)+22	
		1	H= (HF-HF1)+22	
		1	WL=(WF-WF1)-WF2+44	
40.005253.00		2	HF	-
		1	WF	
		1	WF1	
		1	WF2	
40.005129.00		2	HF	-
		1	WF	
		1	WF1	
		1	WF2	

40.191218.00		2	H	-
		1	WL	-
40.200110.00		2	H	-
		1	WL	-
GLASS FIXED 1		1	HF-30	-
			WF1-22	-
GLASS FIXED 2		1	HF-30	-
			WF2-22	-
GLASS FIXED 3		1	HF-22	-
			(WF-WF1)-WF2+14	-
GLASS DOOR		1	(HF-HF1)-32	-
			((WF-WF1)-WF2)-44	-

Accesorios

Accessórios
 Accessories
 Accessoires

10.191209.00	ESCUADRA 90°	8
10.191217.00	CERRADERO	1
12.210712	BISAGRA SIMPLE	3
12.210713	CERRADURA GOLPE Y LLAVE	1
40.001084.00	CALZOS VIDRIO	6

SELEC PUERTAS Y FIJOS
SELEC PORTAS E FIXA
SELEC DOORS AND FIXED
SELEC PORTES ET FIXE

Vistas puertas y marcos fijos
Vistas de portas e armações fixa
Fixed doors and frames views
Vues des portes et des cadres fixe

.1 PLANOS / DRAWINGS

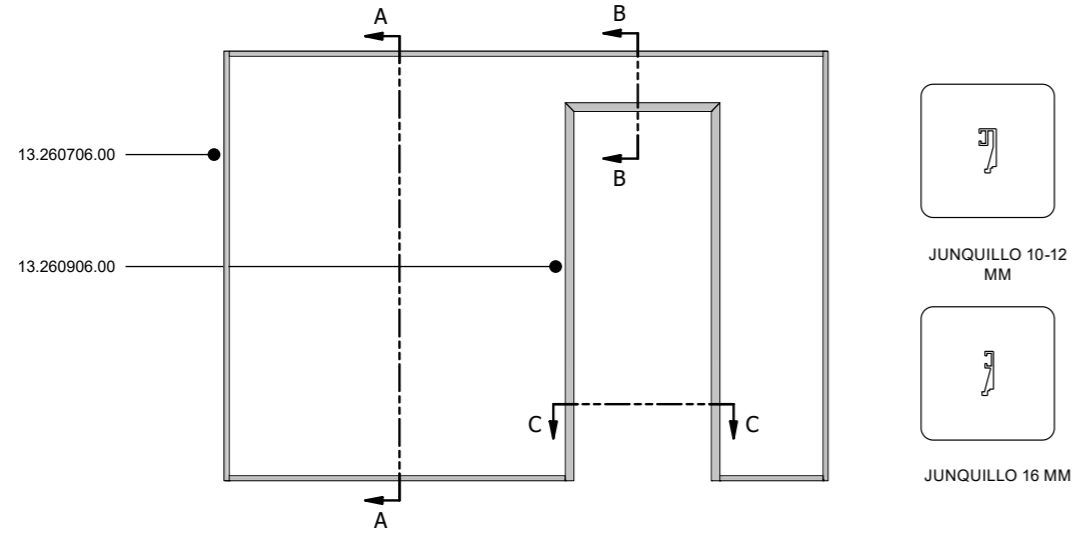

.2 SECCIÓN A-A / SECTION A-A

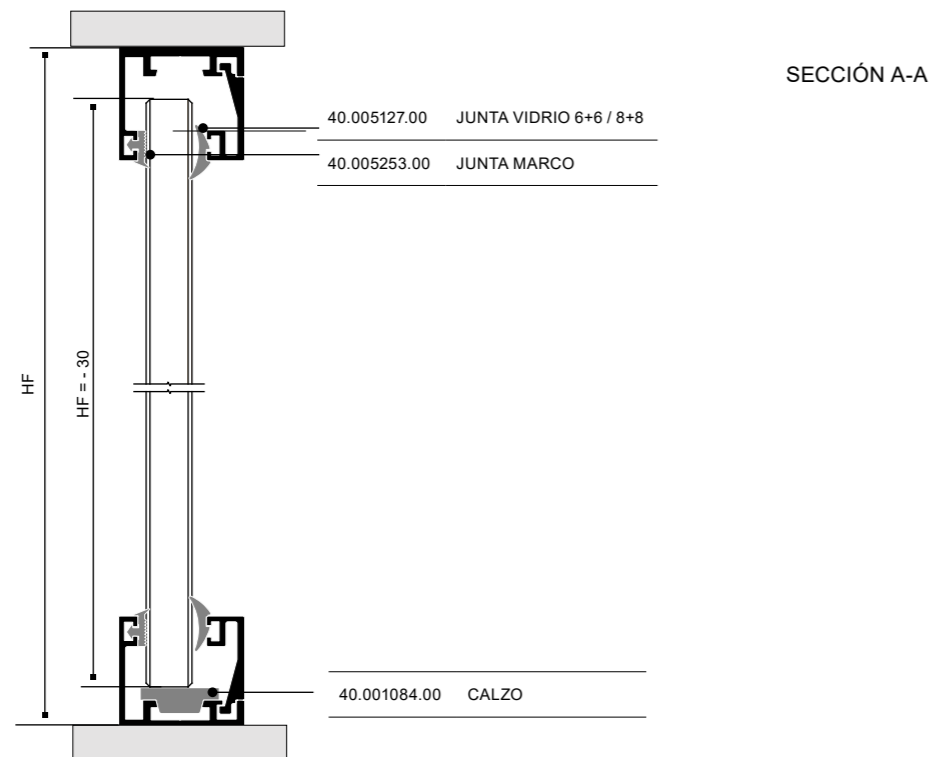

SELEC PUERTAS Y FIJOS
SELEC PORTAS E FIXA
SELEC DOORS AND FIXED
SELEC PORTES ET FIXE

Vistas puertas y marcos fijos
Vistas de portas e armações fixa
Fixed doors and frames views
Vues des portes et des cadres fixe

.2 SECCIÓN B-B / SECTION B-B

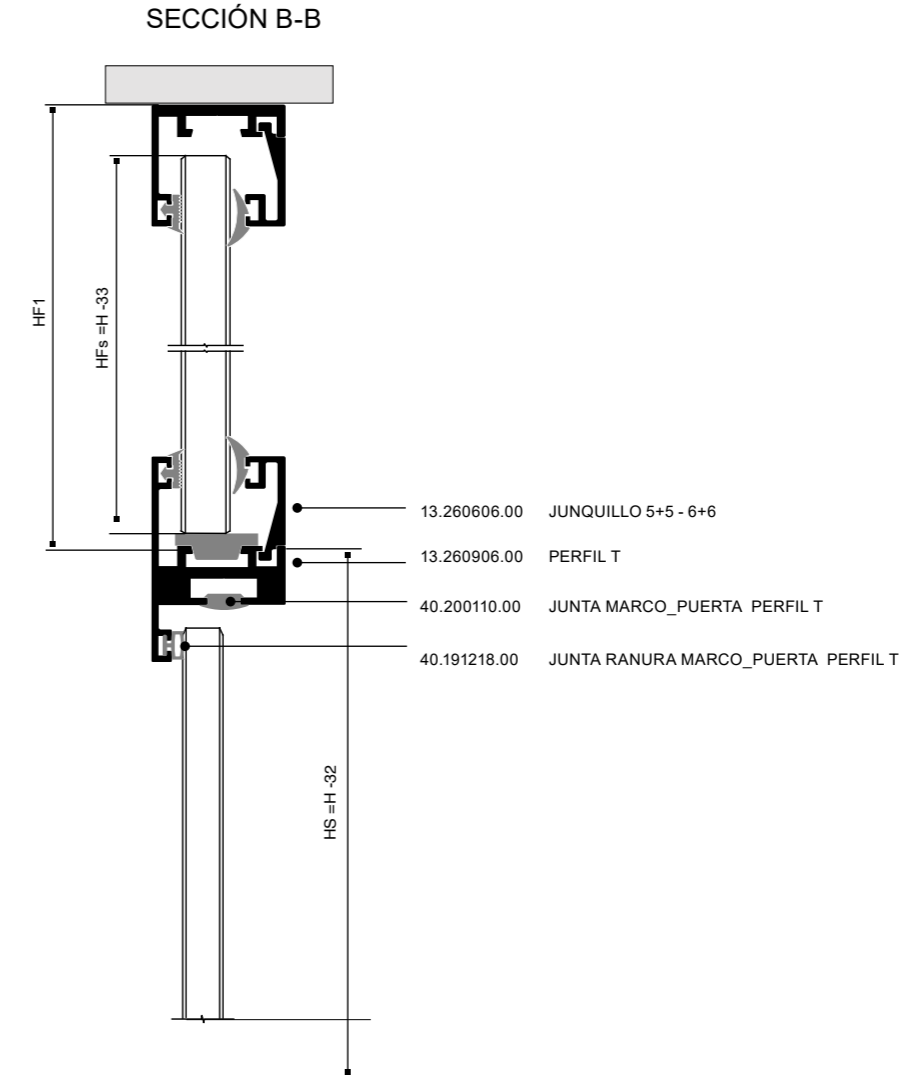

.2 SECCIÓN C-C / SECTION C-C

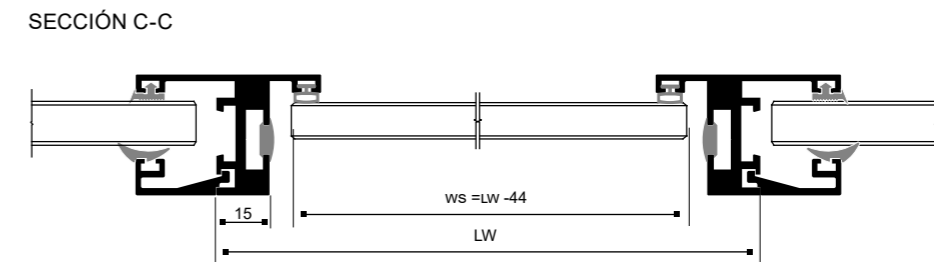

SELEC PUERTAS Y FIJOS
SELEC PORTAS E FIXAS
SELEC DOORS AND FIXED
SELEC PORTES ET FIXES

Vistas puertas y marcos fijos

Vistas de portas e armações fixas
 Fixed doors and frames views
 Vues des portes et des cadres fixes

.1 PLANOS / DRAWINGS

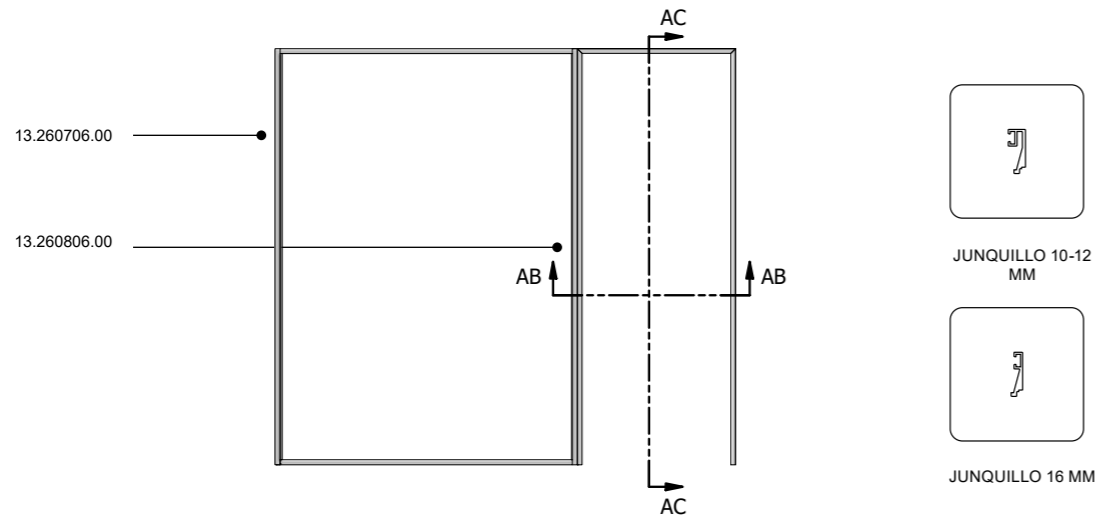

.2 SECCIÓN AC-AC / SECTION AC-AC

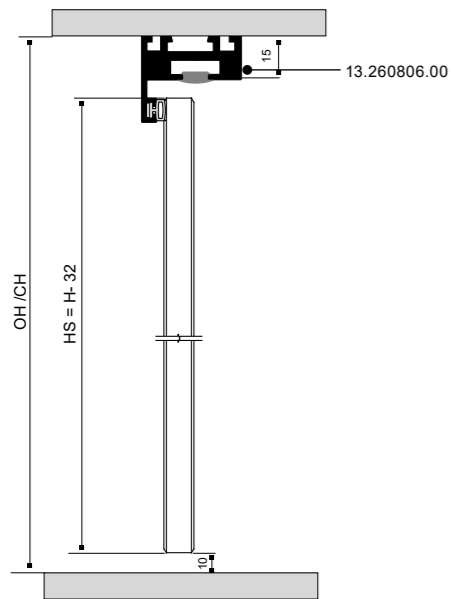

.2 SECCIÓN AB-AB / SECTION AB-AB

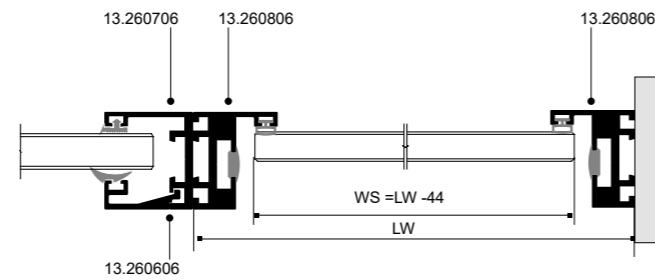

SELEC PUERTAS Y FIJOS
SELEC PORTAS E FIXAS
SELEC DOORS AND FIXED
SELEC PORTES ET FIXES

Vistas puertas y marcos fijos

Vistas de portas e armações fixas
 Fixed doors and frames views
 Vues des portes et des cadres fixes



DETALLE DE UNIÓN DE MARCO 90°



DETALLE DE UNIÓN DE MARCO 45°



LA COLOCACIÓN DE LAS BISAGRAS SE HACE DE FORMA MUY SENCILLA SIN NECESIDAD DE TALADRAR EL MARCO

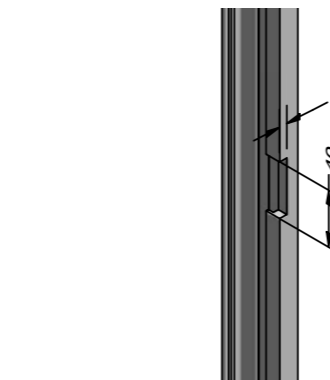

DETALLE MEDIDA FRESADO CERRADERO



FÁCIL COLOCACIÓN DEL CERRADERO

SELEC PUERTAS Y FIJOS
SELEC PORTAS E FIXAS
SELEC DOORS AND FIXED
SELEC PORTES ET FIXES

Vistas puertas y marcos fijos

Vistas de portas e armações fixas
 Fixed doors and frames views
 Vues des portes et des cadres fixes



Colocación del perfil "T" fijándolo al marco con la escuadra 10.191209.00.

Posicionamento do perfil em "T", fixando-o na moldura com esquadro 10.191209.00.

Positioning of the "T" profile, fixing it to the frame with the 10.191209.00 square.

Positionnement du profilé en "T", le fixant au cadre avec l'équerre 10.191209.00.

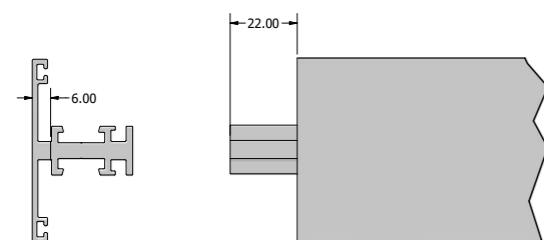

Detalle de fresado perfil "T"

Detalhe de fresagem perfil "T"
 Milling detail "T" profile
 Détail de fraisage profil "T"



SELEC PUERTAS Y FIJOS
SELEC PORTAS E FIXAS
SELEC DOORS AND FIXED
SELEC PORTES ET FIXES

Vistas puertas y marcos fijos

Vistas de portas e armações fixas
 Fixed doors and frames views
 Vues des portes et des cadres fixes

	REF. JUNQUILLO	REF. JUNTA	GRUESO DE VIDRIO
		 40.005129.00	5+5 - 10 ~ 11 MM 6+6 - 12 ~ 13 MM
		 40.005127.00	8+8 16 ~17MM
		 40.005129.00	22 ~ 23MM 25 ~ 26MM
		 40.005129.00	27 ~ 28MM 30 ~ 31MM

SE PUEDEN APLICAR MAS COMPOSICIONES EN VIDRIO , CONSULTAR GOMAS DISPONIBLES

LEYENDA	
OH / CH	ALTURA ÚTIL OBRA
OW	ANCHURA ÚTIL OBRA
H	ALTURA DEL MARCO DE LA PUERTA
LW	ANCHURA DEL MARCO DE LA PUERTA
HS	ALTURA HOJA MÓVIL
WS	ANCHURA HOJA MÓVIL
HF _s	ALTURA FIJO SUPERIOR
WF _s	ANCHURA FIJO SUPERIOR
HF	ALTURA FIJOS LATERALES
WF	ANCHURA FIJOS LATERALES

SELEC MARCO PUERTA
 SELEC ESTRUTURA DA PORTA
 SELEC DOOR FRAME
 SELEC CADRE DE PORTE

Vistas marco puerta
 Vistas do batente da porta
 Door frame views
 Vues du cadre de porte

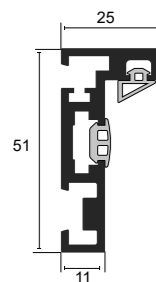

Artículo **22001700**
 Artigo
 Item
 Article

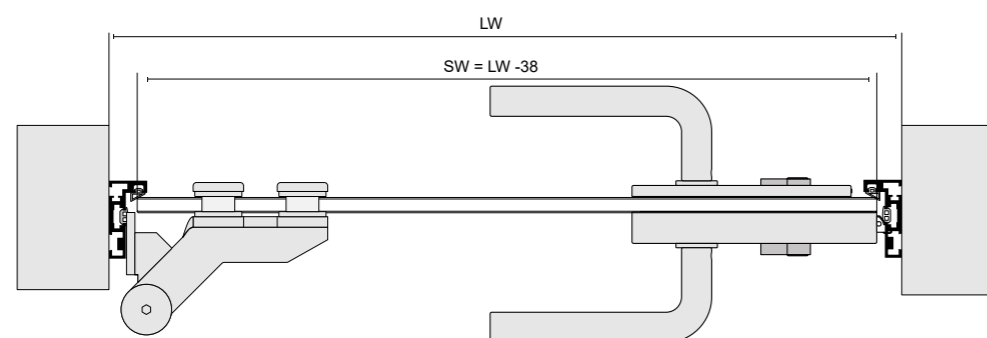
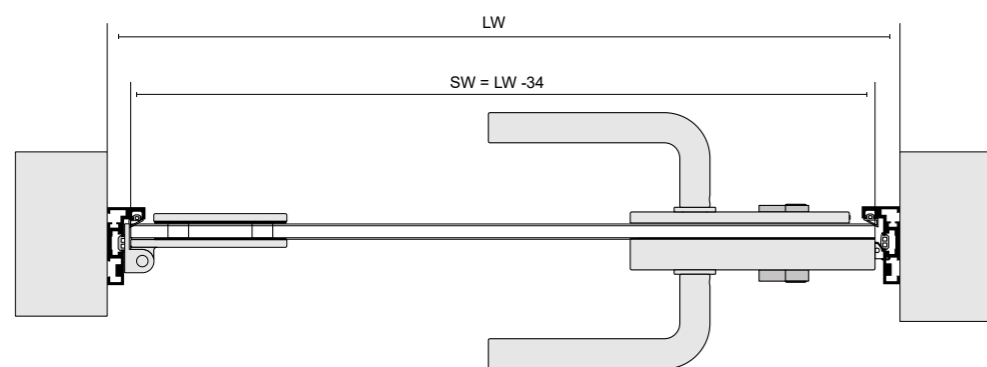

SELEC MARCO PUERTA
 SELEC ESTRUTURA DA PORTA
 SELEC DOOR FRAME
 SELEC CADRE DE PORTE

Vistas marco puerta
 Vistas do batente da porta
 Door frame views
 Vues du cadre de porte

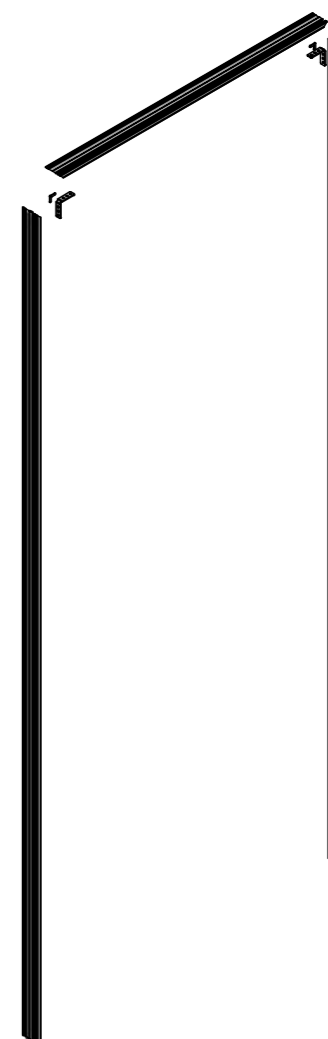

SELEC PUERTA
SELEC PORTA
SELEC DOOR
SELEC PORTE

Despiece, componentes

Vista explodida, componentes
Exploded view, components
Vue éclatée, composants

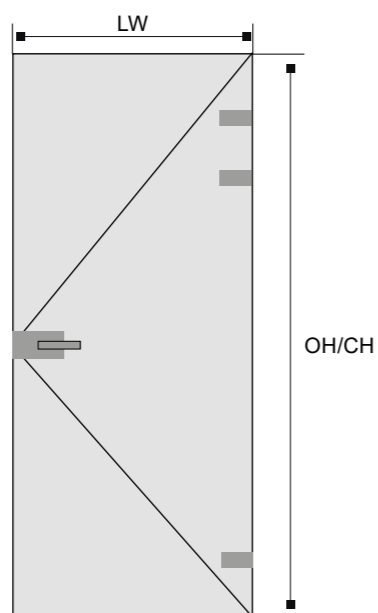

Perfiles

Perfis
Profiles
Profils

Accesorios

Acessórios
Accessories
Accessoires

22001700		1	OH/CH	
		1	OH/CH	
		1	LW= OW-WF	
22052200		2	OH/CH	-
		1	LW	-
40.200110.00		2	H	-
		1	LW	-
GLASS DOOR		1	HS=OH/CH-17	-
			SW=LW-38	-

22111000	JUEGO ESCUADRAS	1
23021800	CERRADERO	1
12.210712	BISAGRA SIMPLE	3
12.210713	CERRADURA GOLPE Y LLAVE	1

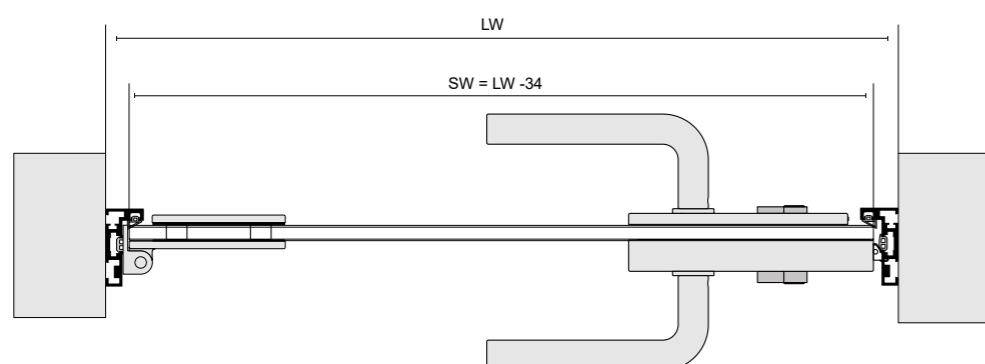

SELEC PUERTA
SELEC PORTA
SELEC DOOR
SELEC PORTE

Despiece, componentes

Vista explodida, componentes
Exploded view, components
Vue éclatée, composants

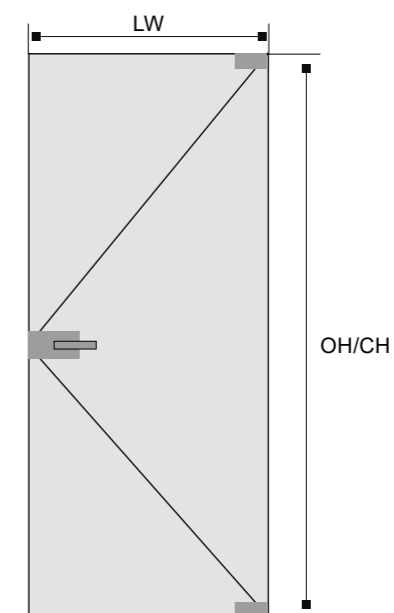

Perfiles

Perfis
Profiles
Profils

Accesorios

Acessórios
Accessories
Accessoires

22001700		1	OH/CH	
		1	OH/CH	
		1	LW= OW-WF	
22052200		2	OH/CH	-
		1	LW	-
40.200110.00		2	H	-
		1	LW	-
GLASS DOOR		1	HS=OH/CH-17	-
			SW=LW-38	-

22111000	JUEGO ESCUADRAS	1
23021800	CERRADERO	1
12.220317	JUEGO PERNIO PIVOTANTE	1
12.210713	CERRADURA GOLPE Y LLAVE	1

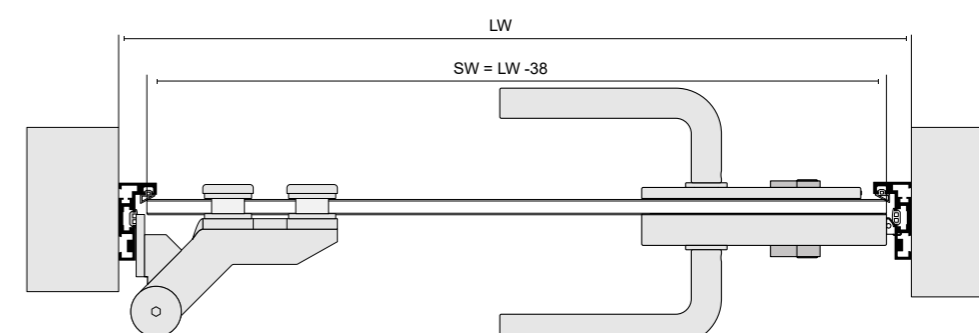

SELEC
SELEC
SELEC
SELEC

Mecanizado
Usinagem
Machining
Usinage

Artículo **12.210713**
Artigo
Item
Article

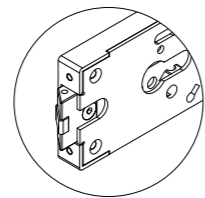
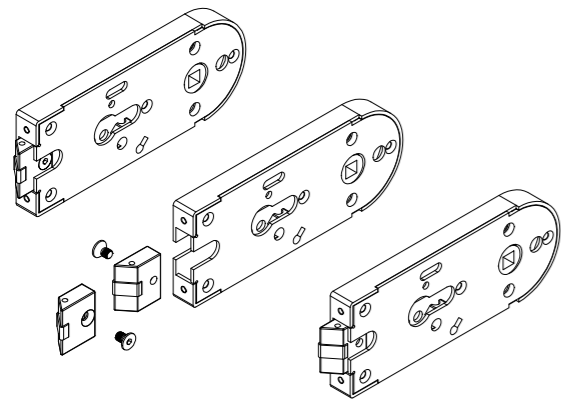
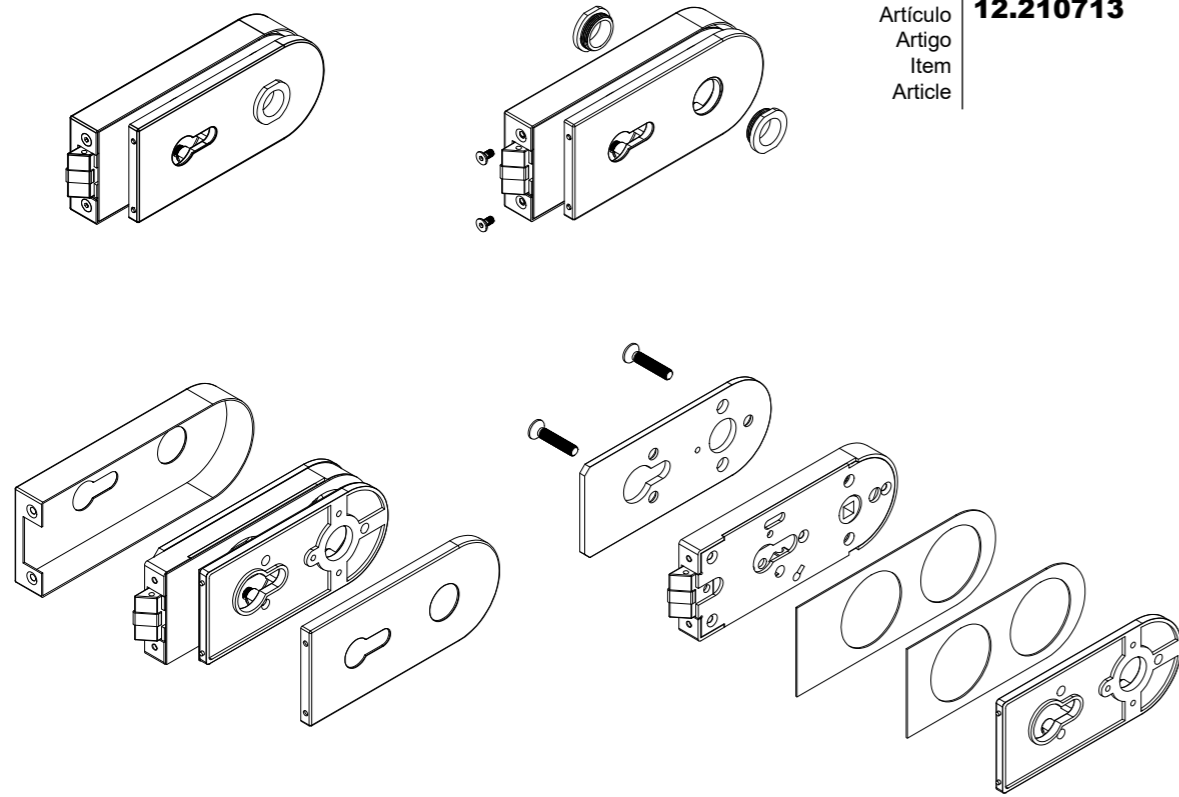

Derecha
Direita
Right hand
Droite

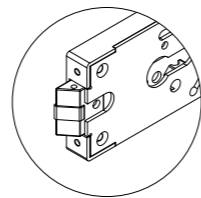

Izquierda
Esquerda
Left hand
Gauche

SELEC
SELEC
SELEC
SELEC

Mecanizado
Usinagem
Machining
Usinage

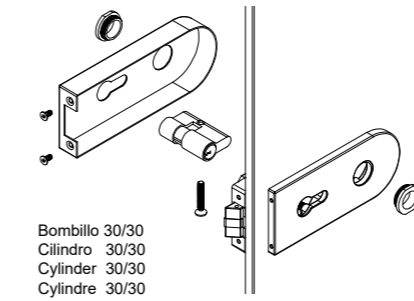
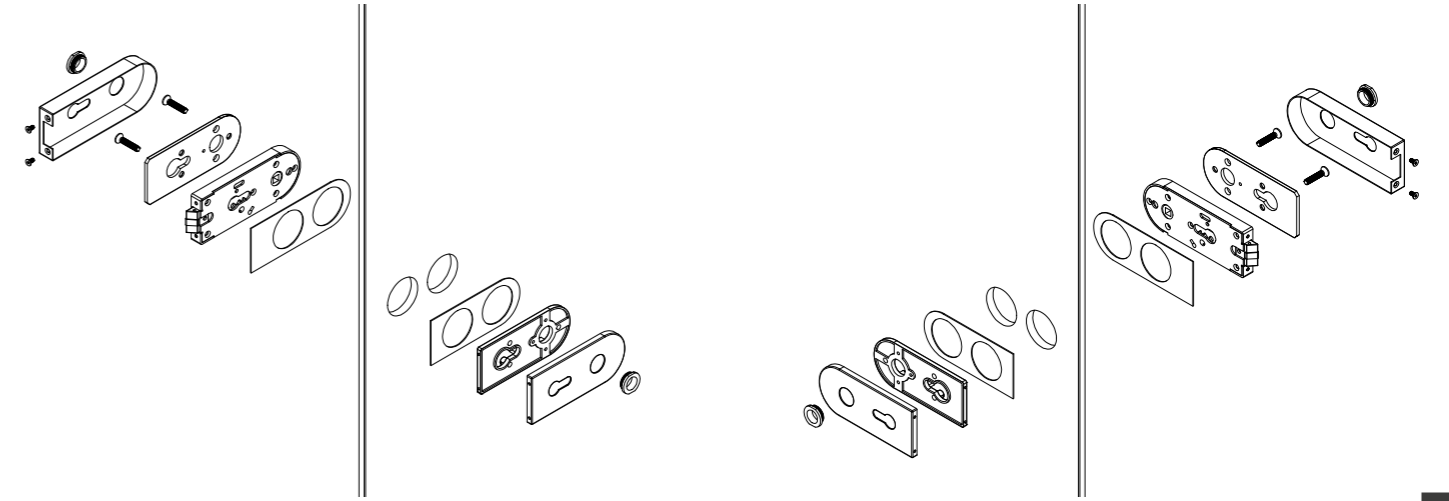

IMPORTANT!
IMPORTANT!
IMPORTANT!
IMPORTANT!

Usar tornillo suministrado M5x35mm
Usar parafuso fornecido M5x35mm
Use supplied screw M5x35mm
Utilisez visse fourni M5x35mm

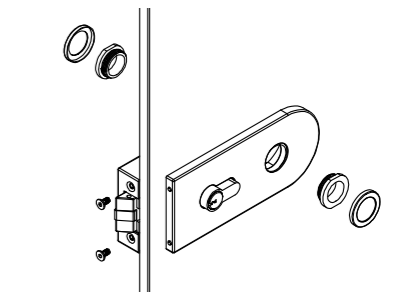

Utilice pieza guía para apretar roseta
Usar peça guia para apertar roseta
Use plastic driver to tighten rose
Utilisez pièce de guidage pour serrer rosette

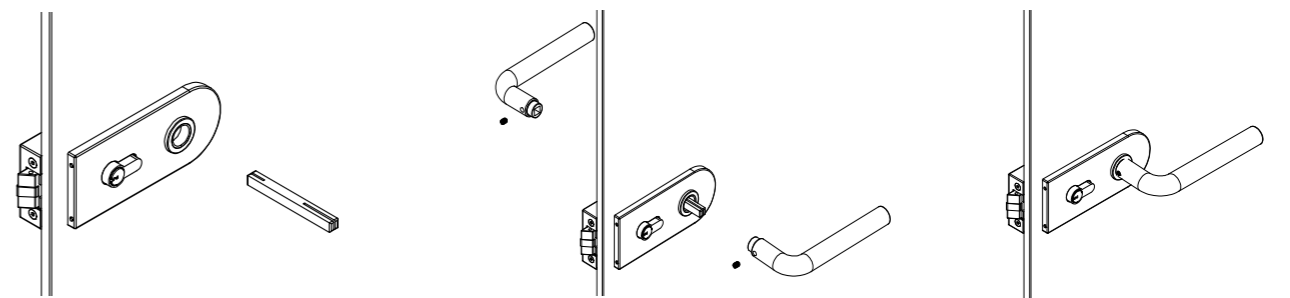

SELEC
SELEC
SELEC
SELEC

Mecanizado
Usinagem
Machining
Usinage

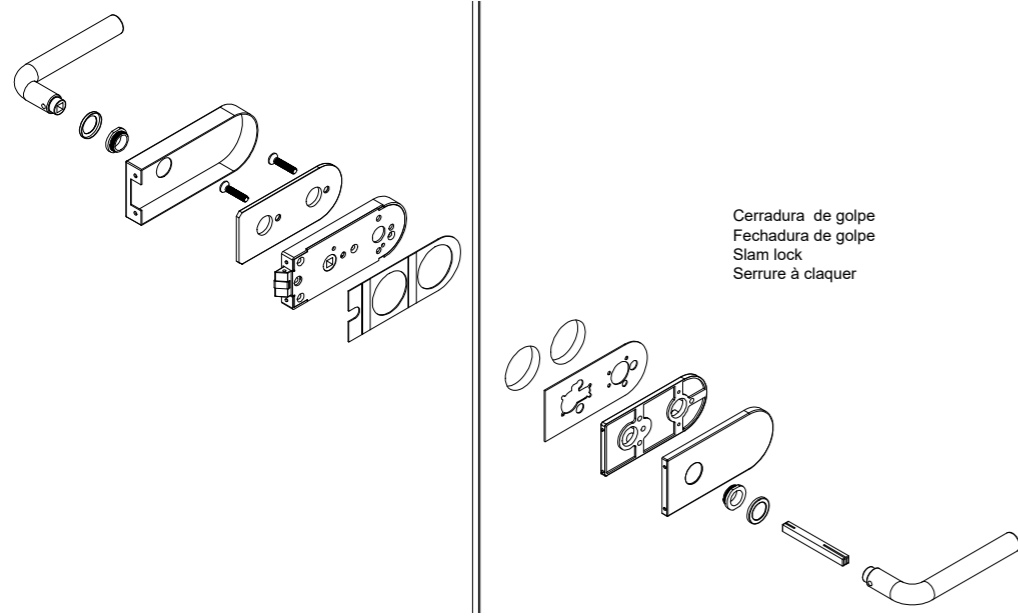

Artículo **12.210715**
Artigo
Item
Article

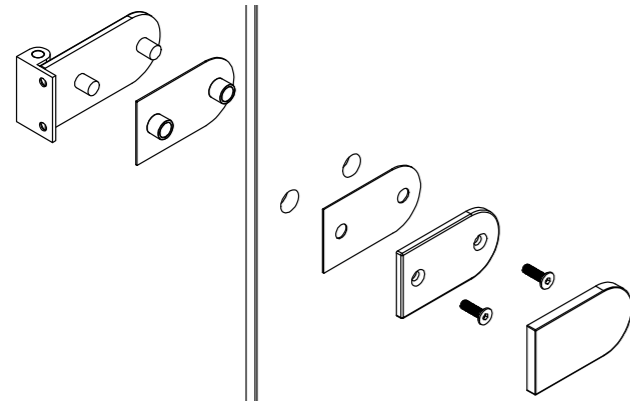
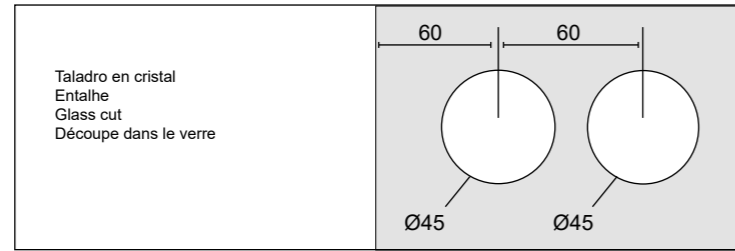

Artículo **12.210712**
Artigo
Item
Article

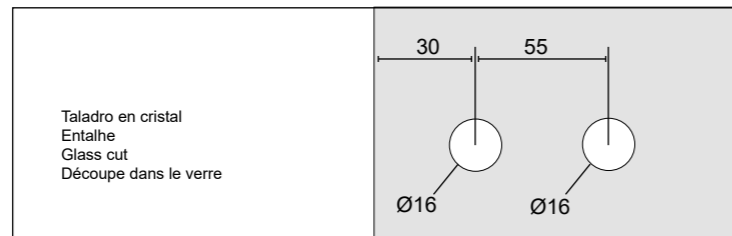

SELEC
SELEC
SELEC
SELEC

Mecanizado
Usinagem
Machining
Usinage



Artículo **12.220317**
Artigo **12.220318**
Item
Article

Jambas

Nuestra colección de jambas ofrece soluciones globales adaptadas especialmente a nuestras series, con opciones para remates embellecedores de tabiquería.

Múltiples versiones para acabados homogéneos en colores y texturas de las instalaciones, en las que el objetivo final versa sobre conseguir una armonización del conjunto, en la que todos los elementos conformen un mismo discurso visual y estético.

Our collection of jambs offers global solutions specially adapted to our series, with options for embellishing finials for partition walls.

Multiple versions for homogeneous finishes in colors and textures of the facilities, in which the final objective is to achieve a harmonization of the whole, in which all the elements make up the same visual and aesthetic discourse.



JAMBAS

Vistas jambas marco

Vistas do batente do quadro
Frame jamb views
Vues de montant de cadre

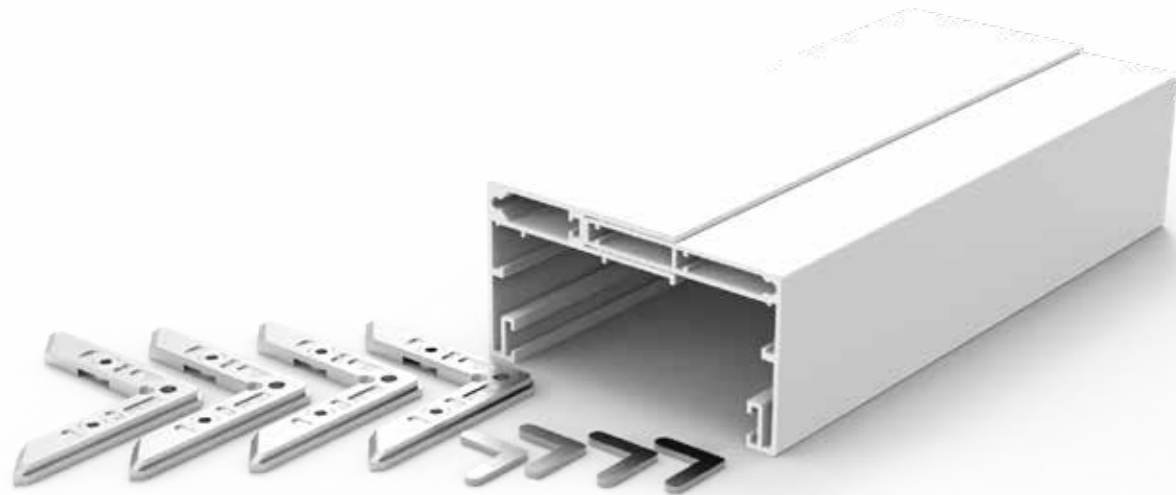

Descripción técnica

Descrição técnica
Technical description
Description technique

La versión de jambas sin galce es aplicable a aquellas situaciones donde se coloca una puerta corredera en su versión frontal o a techo.

Las jambas ofrecen soluciones estéticas como embellecedores de los tabiques con una amplia gama de acabados iguales a las series con las que son compatibles, ELEVA, SELEC y UNE.

A versão de ombreiras sem rebaixamento é aplicável àquelas situações em que uma porta de correr é colocada em sua versão frontal ou teto.

As ombreiras oferecem soluções estéticas como embelezamento de divisórias com uma vasta gama de acabamentos iguais às séries com as quais são compatíveis: ELEVA, SELEC e UNE.

The version of jambas without rebate is applicable to those situations where a sliding door is placed in its front or ceiling version.

The jambas offer aesthetic solutions as embellishments for partitions with a wide range of finishes equal to the series with which they are compatible: ELEVA, SELEC and UNE.

La version des jambages sans feuillure est applicable aux situations où une porte coulissante est placée dans sa version frontale ou au plafond.

Les jambages offrent des solutions esthétiques comme embellissements pour cloisons avec une large gamme de finitions égales à la série avec laquelle ils sont compatibles : ELEVA, SELEC et UNE.

JAMBAS

Vistas jambas marco galce

Vistas do batente da estrutura Galce
Galce frame jamb views
Vues du jambage du cadre Galce

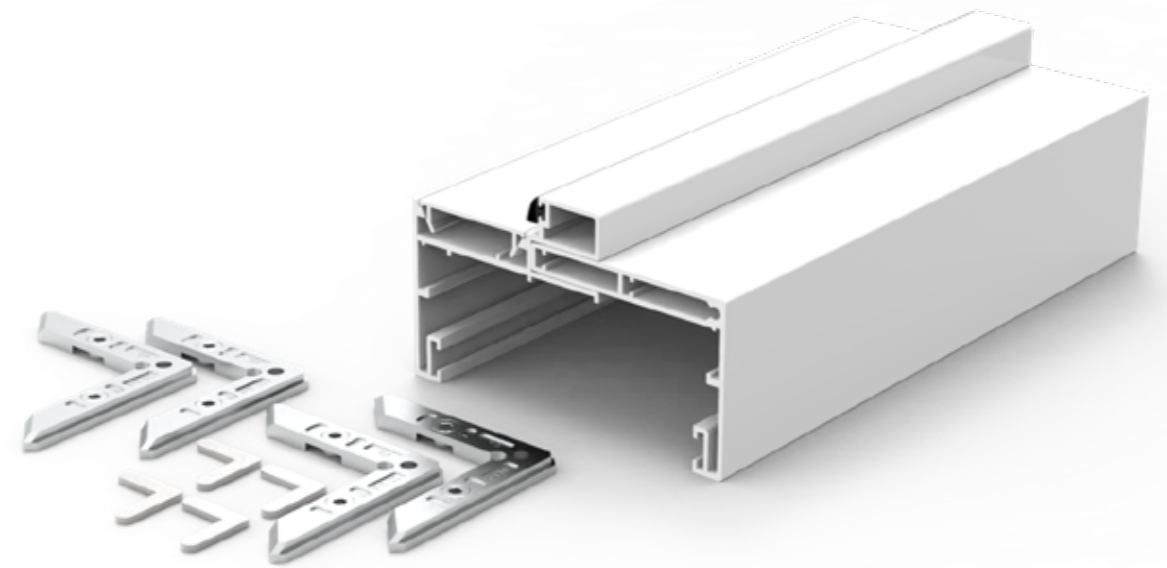

Descripción técnica

Descrição técnica
Technical description
Description technique

La versión con galce es aplicable a instalaciones donde colocamos principalmente puertas batientes en el interior de estancias, como dormitorios, cocinas, baños.

Las jambas ofrecen soluciones estéticas como embellecedores de los tabiques con una amplia gama de acabados.

A versão abatida é aplicável a instalações onde colocamos principalmente portas de batente no interior de divisões, como quartos, cozinhas, casas de banho.

As ombreiras oferecem soluções estéticas como embelezamento de divisórias com uma vasta gama de acabamentos.

The rebated version is applicable to installations where we mainly place swing doors inside rooms, such as bedrooms, kitchens, bathrooms.

The jambas offer aesthetic solutions as embellishments for partitions with a wide range of finishes.

La version à feuillure est applicable aux installations où nous plaçons principalement des portes battantes à l'intérieur de pièces, telles que chambres, cuisines, salles de bains.

Les jambages offrent des solutions esthétiques comme garnitures pour cloisons avec une large gamme de finitions.

JAMBAS

Vistas jambas marco

Vistas do batente do quadro
Frame jamb views
Vues de montant de cadre

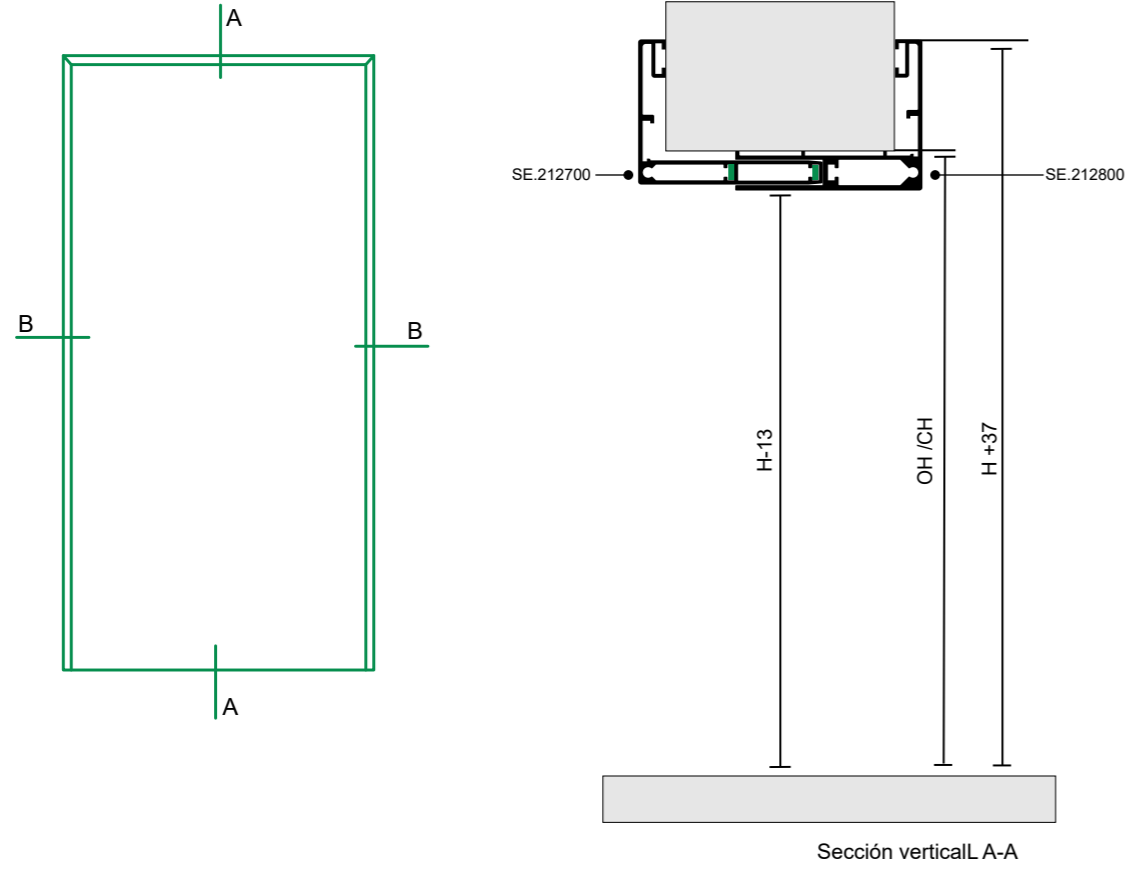

Sección horizontal B-B

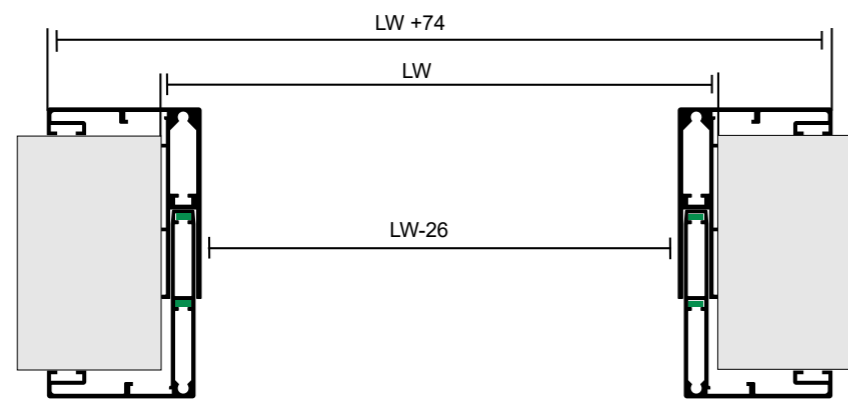

JAMBAS

Vistas jambas marco

Vistas do batente do quadro
Frame jamb views
Vues de montant de cadre

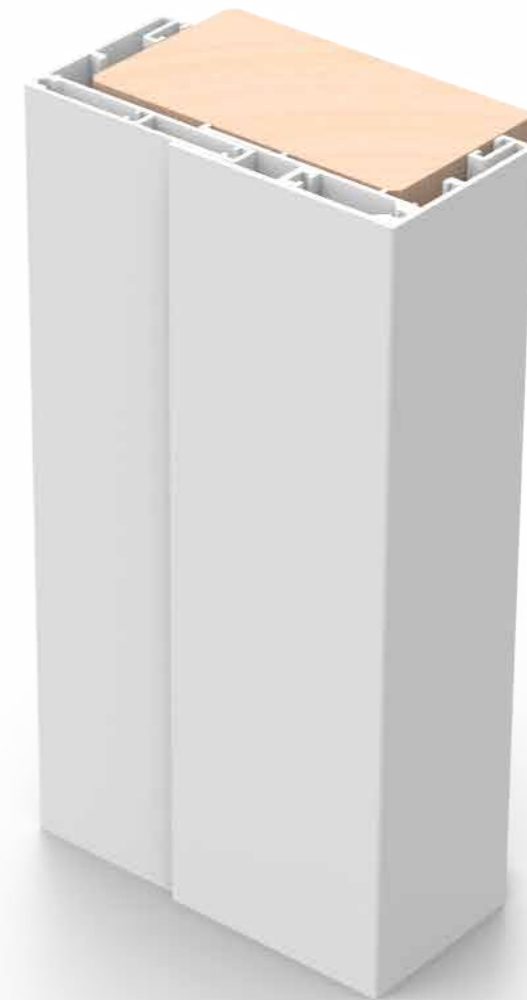

JAMBAS

Vistas jambas marco galce

Vistas do batente da estrutura Galce
Galce frame jamb views
Vues du jambage du cadre Galce

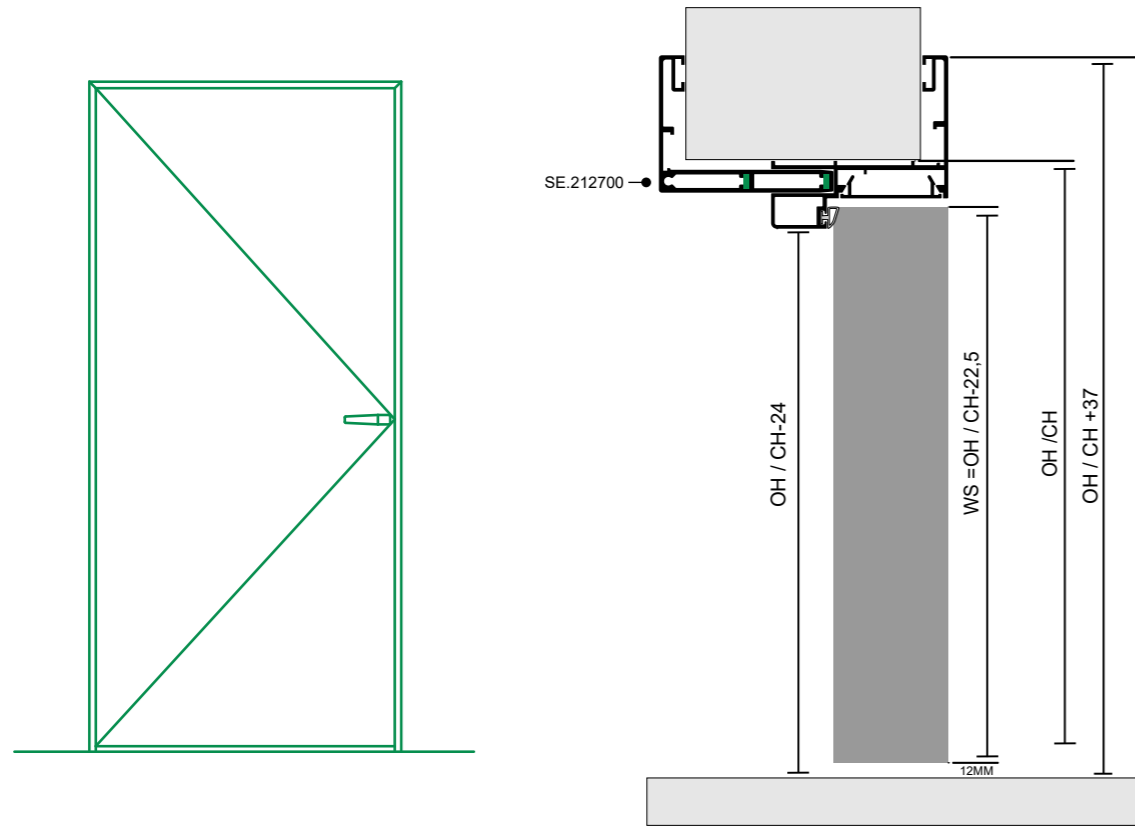

Sección horizontal B-B

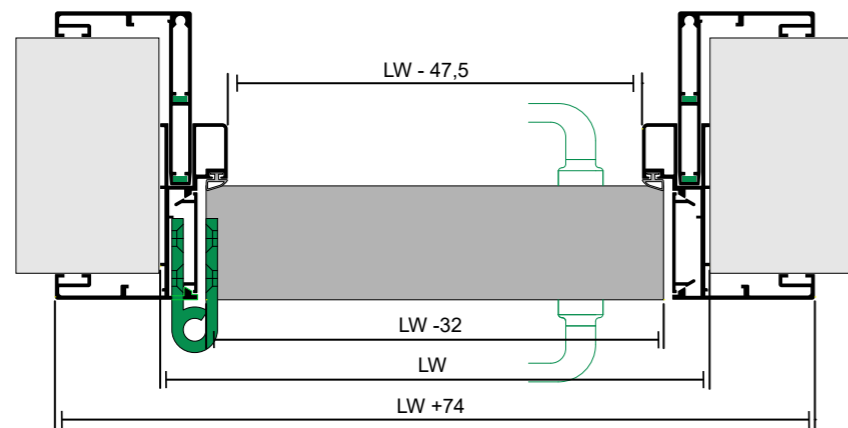

JAMBAS

Vistas jambas marco galce

Vistas do batente da estrutura Galce
Galce frame jamb views
Vues du jambage du cadre Galce



JAMBAS

Cotas y dimensiones de jambas para tabiques

Dimensões e dimensões de ombreiras para partições
Dimensions and dimensions of jambas for partitions
Dimensions et dimensions des jambages pour cloisons

Anchura tabique 76-98 mm

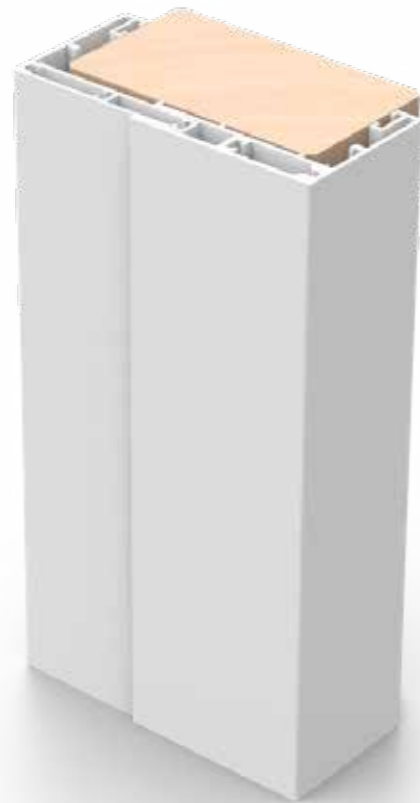

JAMBAS

Cotas y dimensiones de jambas para tabiques

Dimensões e dimensões de ombreiras para partições
Dimensions and dimensions of jambas for partitions
Dimensions et dimensions des jambages pour cloisons

Anchura tabique 76-125 mm



JAMBAS

Cotas y dimensiones de jambas para tabiques

Dimensões e dimensões de ombreiras para partições
Dimensions and dimensions of jambs for partitions
Dimensions et dimensions des jambages pour cloisons

Anchura tabique 76-98 mm

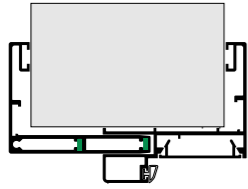

JAMBAS

Cotas y dimensiones de jambas para tabiques

Dimensões e dimensões de ombreiras para partições
Dimensions and dimensions of jambs for partitions
Dimensions et dimensions des jambages pour cloisons

Anchura tabique 76-125 mm

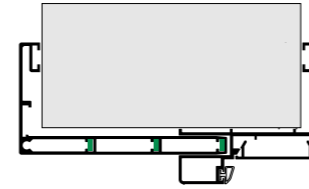

JAMBAS

Cotas y dimensiones de jambas para tabiques

Dimensões e dimensões de ombreiras para partições
Dimensions and dimensions of jambas for partitions
Dimensions et dimensions des jambages pour cloisons

Anchura tabique 107-150 mm

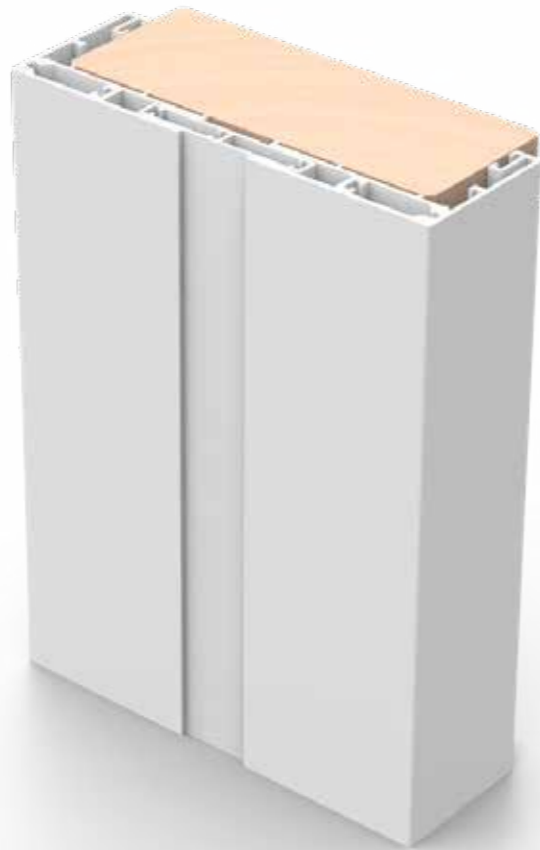
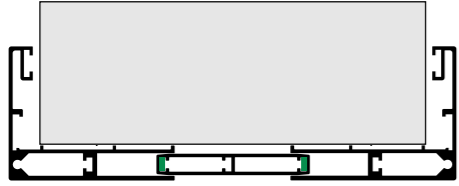

Eix Empresarial
c/ Indústria, 30
Pol. Ind. La Quintana
08504 Sant Julià de Vilatorça
Barcelona

T. 93 886 93 18
comercial@dicosl.com
dicoglass.com

OGC se reserva el derecho en todo momento de aplicar modificaciones para la mejora funcional o cualitativa de sus productos. Los textos y dibujos presentes en este folleto tienen un propósito informativo: para cada aspecto técnico y dimensional, consulte las listas de precios de la compañía y sus actualizaciones relativas. Las muestras y MQ (maquetas), de color y material tienen un valor indicativo.

OGC reserves the right at all times to apply modifications for functional improvement or qualitative quality of your products. The texts and pictures in this brochure have a purpose informative: for each technical and dimensional aspect, consult the company's price lists and their relative updates. Color and material samples are indicative value.

TÜVRheinland®



Management
System
ISO 9001:2015
www.tuv.com
ID 9105070165



Diseño de producto / realización: OGC
OGC 2021.V01
Todos los derechos reservados.

